



**MAX.  
200sqm/h**

***FABRIJET***

**HS FT**

**HIGH SPEED FABRIJET TRANSFER**



See product information from DGI App & DGI facebook



## Technical Specification

<b>Print Speed</b>	Draft Mode 200 m <sup>2</sup> /hr	Production Mode 115 m <sup>2</sup> /hr	Quality Mode 80 m <sup>2</sup> /hr	High Quality Mode 62 m <sup>2</sup> /hr
<b>Print Resolution</b>	600 x 300dpi (1 Pass)	600 x 600dpi (2 Pass)	600 x 900dpi (3 Pass)	600 x 1,200dpi (4 Pass)
<b>Max Print Width</b>	1,850 mm			
<b>Max Media Width</b>	1,900 mm			
<b>Print Mode</b>	Bi-Direction / Uni-Direction , Normal / Interleave I, II / DBF I, II, III			
<b>Printhead</b>	Kyocera Printhead (2 heads)			
<b>Color</b>	4 Color - Cyan, Magenta, Yellow, Black			
<b>Ink</b>	DGI original water based F120 / F131 Dye Sublimation Ink			
<b>Interface</b>	TCP / IP			
<b>Environmental Range</b>	Temperature : 20~28 °C		Humidity: 40~70%	
	Environment condition may affect on final printing quality.			
<b>Electricity Requirements</b>	Printer : 220~240V VAC Single Phase, 50/60 Hz / 10A		Winder & Refill : 220~240V VAC Single Phase, 50/60 Hz / 3A	

※ All specifications are subject to change without notice.

## Dimension for Installation

	Uncrated				Crated			
	Length (mm)	Width (mm)	Height (mm)	Weight (kg)	Length (mm)	Width (mm)	Height (mm)	Weight (kg)
<b>Printer</b>	4,000	900	2,070	1,200	4,400	1,330	2,100	1,600
<b>Winder &amp; Refill</b>	2,810	630	810	200	3,440	900	1,100	350

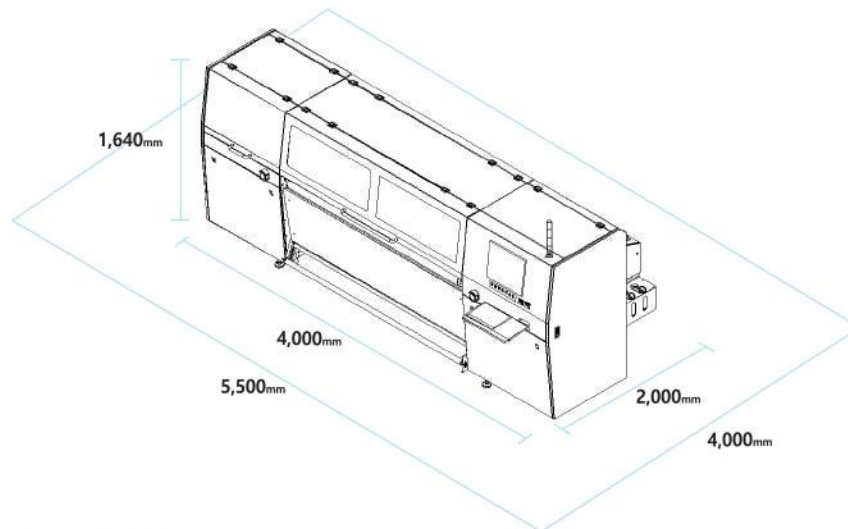

## DGI Original Ink

MODEL	F120 (Standard Original)	F131 (Premium Original)
<b>Type</b>	Water based Dye sublimation	Water based Dye sublimation
<b>Capacity</b>	5Kg / Bottle	1Kg / Bottle
<b>Color</b>	C, M, Y, K and Cleaning Solution	C, M, Y, K and Cleaning Solution
<b>Package</b>	3 Bottles / Box	16 Bottles / Box



52, Cheongdam-Ro, Yangju-si, Gyeonggi-do, Korea, 482-020  
 TEL : +82-31-820-8900 A/S : +82-31-820-8880  
 FAX : +82-31-820-8990 E-MAIL : sales@dgi-net.com  
[www.dgi-net.com](http://www.dgi-net.com)  
[www.facebook.com/dgikorea](https://www.facebook.com/dgikorea)



ISO 9001:14001 Certified